

A 300 V Mercury Switch Pulse Generator with 70 Psec Risetime for Investigation of UHF PD Signal Transmission in GIS

S.M. Neuhold, H.R. Benedickter, M.L. Schmatz

High Voltage Engineering Symposium, 22-27 August 1999, London
Conference Publication No. 206, IEE ,1999

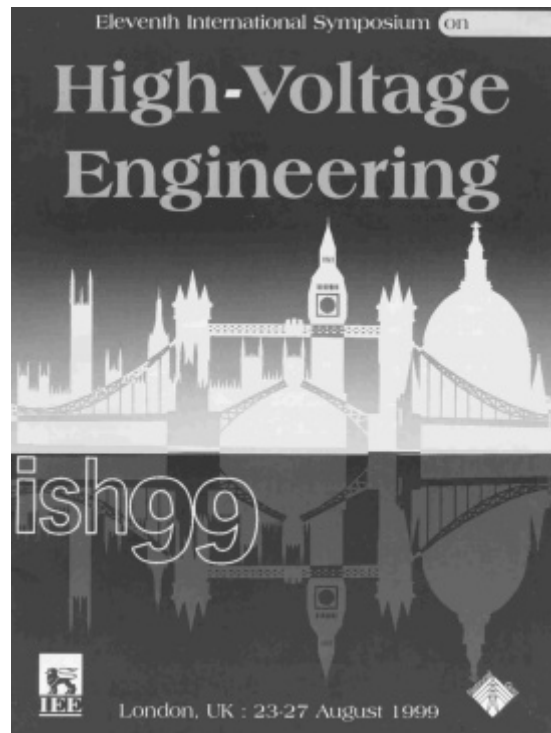

Volume 5, Page No 78, Session No. S12 (Oral-Session)

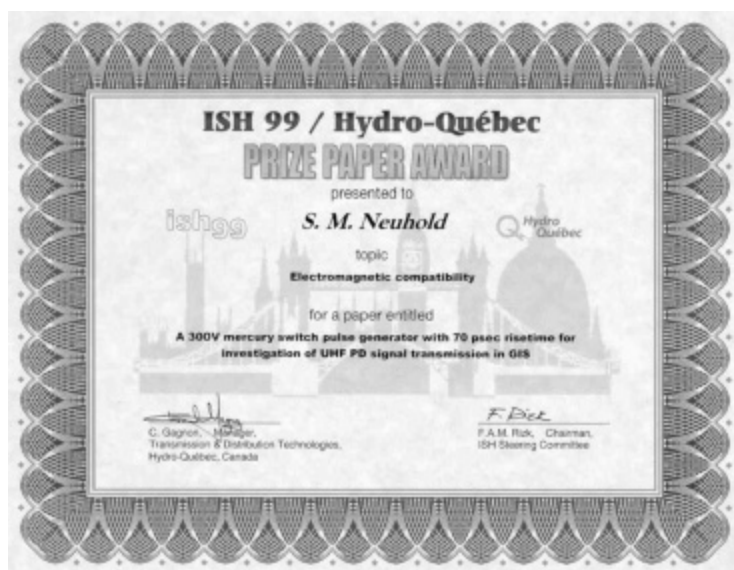

Prize Paper Award for Topic Electromagnetic Compatibility

A 300 V MERCURY SWITCH PULSE GENERATOR WITH 70 PSEC RISE TIME FOR INVESTIGATION OF UHF PD SIGNAL TRANSMISSION IN GIS

S. M. Neuhold, H.R. Benedickter[★], M. L. Schmatz[★]

FKH Zurich, Voltastrasse 9, CH-8044 Zurich, Switzerland

[★]ETH Zurich Lab. for Electromagn. Fields and Microwave Electronics, Gloriastrasse 35, CH-8092 Zurich Switzerland;

email: neuhold@fkh.ch

Abstract

A Mercury switch pulse generator for the purpose of high frequency characterization of Gas Insulated Switchgear (GIS) is presented. The compact device is well matched to 50 Ω and operates with a DC voltage of 300 V. It consists of a charged cable, a fast mercury switch relay and supporting passive elements.

With this combination, a 150 V pulse may be applied to a GIS Partial Discharge (PD) sensor with a 70 ps rise time and a 50 ns pulse length, having a maximum repetition rate of more than 100 Hz.

The robust device is light-weight and easy to handle. Due to its modular design, it may be directly connected to a GIS PD sensor. It may be used for the simulation of PD discharges in GIS, for impulse propagation speed measurements and for the sensitivity check of GIS PD sensors together with UHF PD measurement systems.

Keywords: mercury switch, picosecond, pulse generator, Gas insulated switchgear, GIS, Partial discharges, PD, Ultra high frequency, UHF, SF6

Introduction

The spectrum of PD signals in GIS contains relevant frequency components above 3 GHz [1, 2]. To check the sensitivity of installed PD sensors in GIS, artificial pulses are injected into one PD sensor and measured at the other sensors [3, 4]. A calibration of the UHF-method is not possible [5]. Up to now, pulse generators were used with rise time of 200 psec – 400 psec [1, 6, 7]. According to formula (1), this results in a frequency spectrum limitation of 0.9 GHz to 1.4 GHz [8].

$$\text{Formula 1: } f_{3\text{dB}} = 0.35 / t_r$$

When injecting a charge Q into a GIS via PD sensor, the capacity C_1 of the PD sensor to the center conductor determines the pulse amplitude of the

artificial PD signal [4]. For some sensor designs, the value of C_1 is small (0.15 pF). To apply a charge of 15 pC, a pulse amplitude of 100 V is necessary. This results in a charging voltage of 200 V for a cable pulse generator design [4]. Many pulse generators have a maximum output voltage in the range of only 5 V – 50 V [1, 9]. The attenuation of propagating PD-Signals in GIS increases considerably towards higher frequencies [7, 10]. This fact allows a rough localization of the PD source via the measurement of the power spectrum of the PD signal. On the other hand, some constructive parts of the GIS (circuit breakers, disconnectors) lead to a high damping of high frequency signals [7]. To study the frequency damping characteristics of a GIS design and to get information for possible PD source localization, it is important to use a pulse generator with high amplitude (to reach the most distant sensor) and a spectrum as similar as possible to a real PD-source. The pulse generator should be connected as close as possible to the PD sensor to reduce signal distortion and skin effect damping [11]. With standard pulse generators, this is very difficult due to their weight and/or size.

What would be needed is a small, light-weight pulse generator with very short rise time (< 100 psec), high signal amplitude (> 200 V) and a maximal repetition rate of approximately 100 Hz. It should be possible to connect the switch very close to the PD sensor and to synchronize it with 50 Hz / 60 Hz or with an arbitrary frequency (e. g. of a resonant high voltage testset) up to 100 Hz.

Design

The realized pulse generator consists of a mercury switch relay, connecting a DC charged cable to the output (Fig. 1). All components are well matched to 50 Ω . Due to the mercury wetted contacts, no bouncing occurs. The closing and opening of the mercury switch is controlled with a coil. Between charging cable and DC supply, a matching circuit

M_2 is connected to eliminate reflections and to control the charging time.

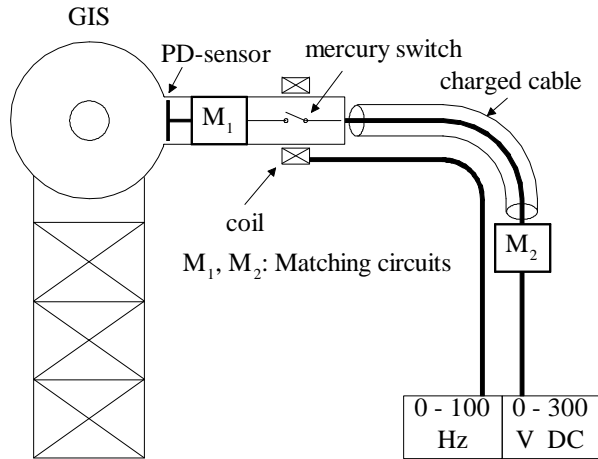

Fig. 1: Design of the pulse generator

The mercury switch, together with a matching circuit M_1 can be connected directly to a GIS sensor (Fig. 2). The charging cable with the matching circuit M_2 and the supply cable for the coil may be connected via long cables to the coil driver unit and the charging unit. This has the advantage, that the mercury switch of the pulse generator is connected as close as possible to the PD-sensor. Due to the small size of all components, the device (mercury switch with matching unit) can easily be connect ed directly to PD sensors, even at hardly accessible locations of the GIS with limited space or at high locations.

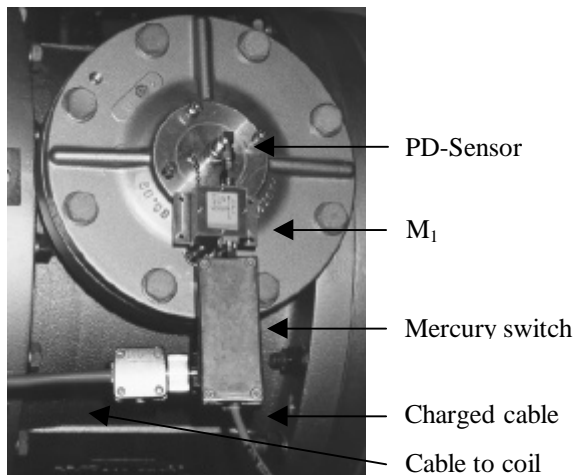

Fig. 2: Mercury switch with matching unit connected to a PD sensor

Fig. 3 shows the pulse generator circuit. The charging cable is connected via a charging resistor R_3 at a DC voltage level of U_1 . Closing the mercury switch by energizing the coil, a pulse with an amplitude of $\frac{1}{2} * U_1$ is applied to the PD sensor. The resistor R_1 to ground between mercury switch and PD sensor discharges the PD sensor with a time constant several orders of magnitude higher than the risetime and duration of the pulse.

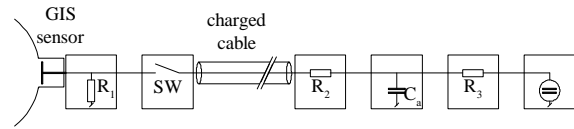

Fig. 3: Pulse generator circuit

Performance

Fig. 4 shows the measured rise time of the pulse generator at a charging voltage of 300 V and a repetition rate of 100 Hz. To measure the risetime (10% - 90% of the peak amplitude), a 6 GHz sampling oscilloscope with internal delay line together with a 40 dB attenuator was used (Tektronix TDS 820). The rise time of the oscilloscope was calculated (Formula 1) to measure 58 psec.

Due to the fact, that the measured rise time (t_r) of approximately 70 psec is very close to the rise time of the oscilloscope (t_{osz}), the effective rise time (t_r') of the pulse generator can be estimated to approximately 35 psec [9,12].

$$\text{Formula 2: } t_r' = \sqrt{t_r^2 - t_{osz}^2}$$

(Assuming fist order spectrum decay at high bandwidth limit)

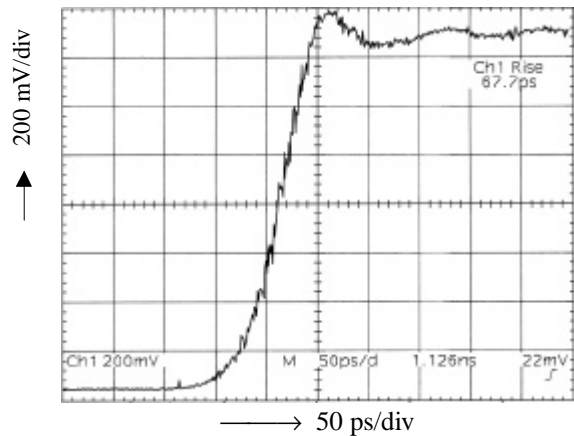

Fig. 4: Measured rise time of pulse generator

In Fig. 5, the pulse shape is shown, with a length of the charging cable of 1 meter. The length of the pulse is a function of the capacitance C_a in Figure 3.

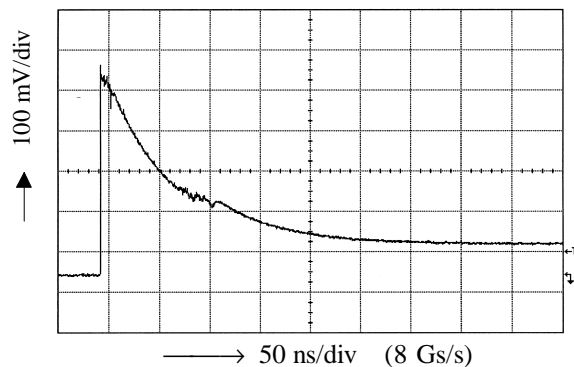

Fig. 5: Pulse shape with a charging cable of 1 meter.

The very fast rise time of the realized pulse generator is a direct result of the optimized source impedance

match to 50Ω . The mercury switch is mounted in a coaxial system minimizing any unwanted reflections. Fig. 6 shows the measured source match of the closed mercury relays. Up to 3 GHz, the measured reflection coefficient was better than -17 dB. This guarantees that any energy reflected by an unmatched sensor is dissipated in the source and no significant re-reflections disturb the measurement. This is not the case with traditional designs where no cable termination is used on the source side of the pulse generator. No matching resistor is needed after the switch. This results in higher signal amplitude and makes the design independent of the load reflection coefficient. Even with a PD sensor other than 50Ω impedance, no multiple pulse reflections are generated. This is very important because such multiple injected pulses could not be separated from a GIS reflection measured on another PD sensor.

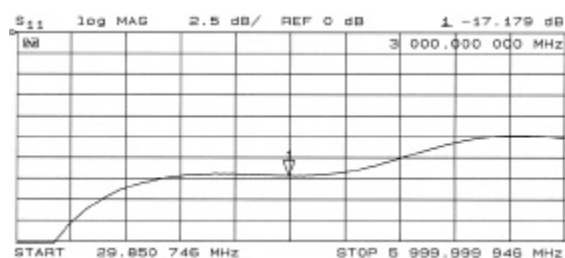

Fig. 6: Source reflection of the mercury switch

Figure 7 and 8 demonstrate, that the reflected signal from the sensor is almost as large as the generated pulse. The good match of the pulse generator is responsible for the attenuation of the re-reflection by a factor of 5.

However, plate sensors used in wide spread GIS are not optimized for broad band signal transmission. Thus only parts of the spectrum at typical sensor resonance frequencies are in fact transmitted in both directions (Fig.9). This imposes certain restrictions to the PD scaling with plate type sensors. Nevertheless, better sensor designs with other shapes (conical, stripline) are already available and will preferably be used in the future.

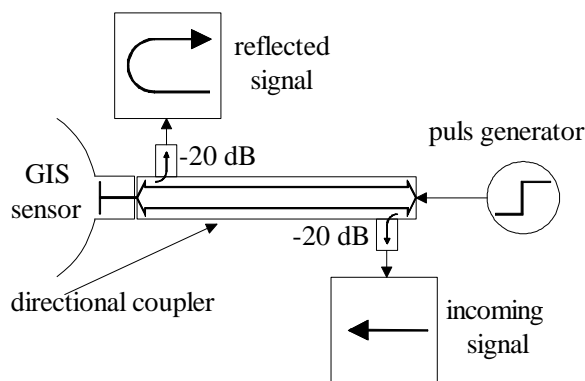

Fig. 7: Measurement setup for the determination of the pulse reflection at the sensor

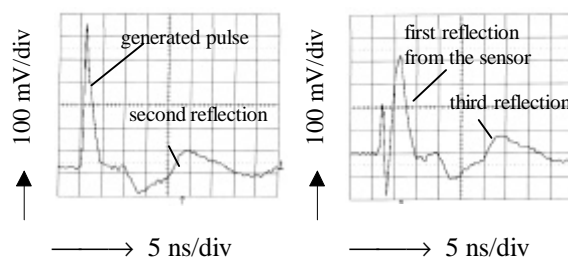

Fig. 8: Measured pulse forms of the incoming and the reflected signal (Fig. 7)

The repetition rate of the pulse generator can be extended to 110 Hz. The maximal possible charging voltage (limited by the passive matching components and the mercury switch) has not yet been evaluated, but is certainly above 300 V.

Simulation of PD Discharges

The pulse generator design was tested on a 170 kV GIS substation having 12 PD sensors. At one PD sensor (capacity of sensor disk to center conductor: 0.15 pF), pulses of 100 V were applied, resulting in a 15 pC charge injection. On the adjacent sensor, the signals were measured with a wide bandwidth (0.1 - 1.8 GHz) measurement system. The frequency spectrum measured (Fig. 9) shows high signal energy between 1.3 GHz and 1.7 GHz. Therefore it is essential for this type of sensor to have a pulse generator with a frequency spectrum up to 2 GHz.

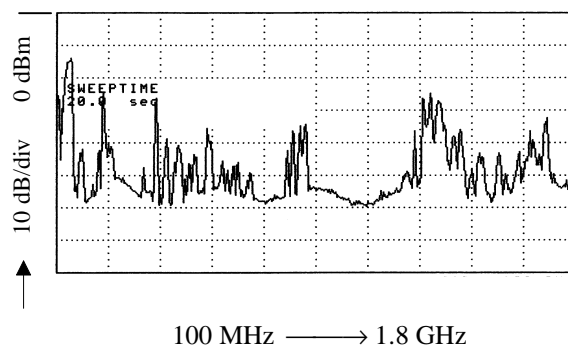

Fig. 9: Injection of pulse in a PD sensor: measured spectrum at the adjacent sensor

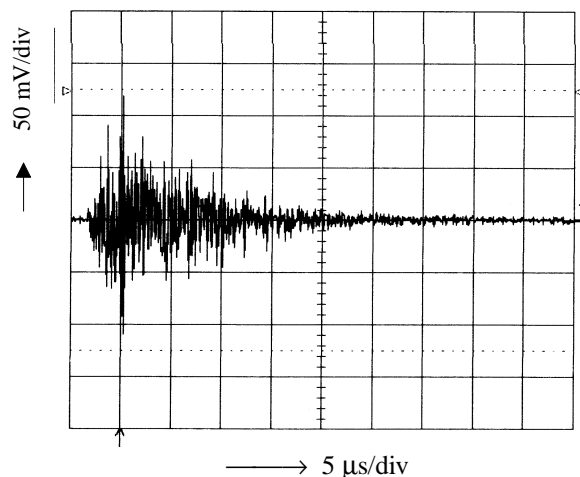

Fig.10: Sensitivity check of PD detection in GIS

Given a certain layout of PD sensor placement, it is proposed to perform a sensitivity check of the PD measurement to determine the sensitivity for all locations in the GIS [3]. To scale the PD sensitivity an artificial PD pulse is injected via one PD sensor and measured at another PD sensor. Figure 10 shows the measured artificial PD pulse at a PD sensor which is injected at the adjacent PD sensor. With a coupling capacity of the sensor disk to the center conductor of 0.15 pF and a pulse amplitude of 33 V, a charge of 5 pC is injected.

Simulation of PD source localization

To simulate a PD source localization procedure, impulse propagation speed measurements have been carried out on a GIS in service. Fig. 11 shows the experimental setup, fig 12 presents the measured waveforms. With a wide band (0.1 – 1.8 GHz) measurement system, a source localization accuracy of approx. 30 cm was obtained using an oscilloscope with 600 MHz bandwidth.

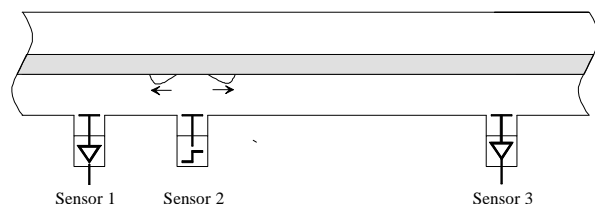

Fig. 11: Measurement setup for simulation of localization measurement. PD like pulses injected in sensor 2 and registered at sensors 1 and 3

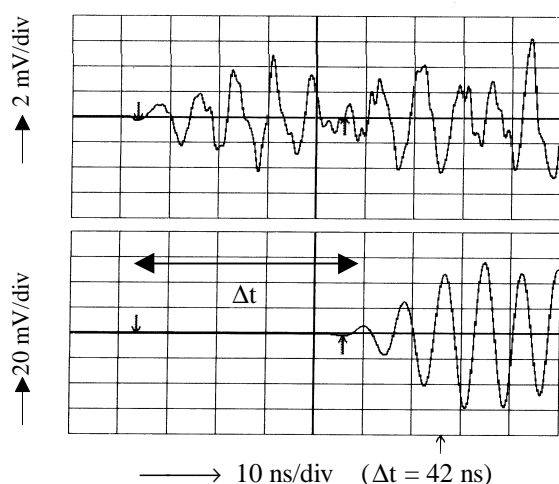

Fig. 12: Simulation of PD source localization: Waveforms

Conclusions

A modular mercury switch pulse generator for GIS HF characterization was realized. A rise time of < 70 psec and a pulse length of approximately 50 nsec were measured with a DC input voltage of 300 V and a pulse repetition rate of 100 Hz. The circuit is well matched to 50 Ω, therefore multiple reflections can

be excluded with this design. This implies that the transferred pulse into the GIS is much more reliable compared to earlier designs.

Due to the fact, that the measurement rise time of approximately 70 psec is very close to the rise time of the oscilloscope, the effective rise time of the pulse generator it is supposed to be even shorter than 70 psec.

References

- [1] R. Kurrer, R.Feger, K. Feser: The Application of UHF-Impulses for Testing UHF PD Measurement Systems applied to Gas-Insulated Substations. CIGRE 1997, Joint TF 15/33.03.05 IWD Feser 4
- [2] G. Wanninger: Apparent Charge Measurement in GIS by Modern Diagnostic Methods. ETEP Vol. 7, No. 4, July/August 1997
- [3] CIGRE 1998 TF 15/33.03.05 IWD 73: Sensitivity Verification for Partial Discharge Detection on GIS with the UHF and the Acoustic Method.
- [4] Albiez, M.: Teilentladungsmessung an SF6-isolierten Schaltanlagen. ETH Zurich, Switzerland, 1992, Thesis Nr. 9694.
- [5] Sellars, A.G., MacGregor, S.J., Farish, O.: Calibrating the UHF Technique of PD Detection using a PD simulator. IEEE Trans. on Dielect. and El. Ins., Vol. 2, No. 1, 1995, pp. 46-52.
- [6] S. Meijer, E. Gulski and W.R. Rutgers: Evaluation of Partial Discharge Measurements in SF6 Gas Insulated Systems. 10th International Symposium on High Voltage Engineering, Montreal 1997
- [7] Behrmann, G.J.; Neuhold, S., Pietsch, R.: Results of UHF measurements in a 220 kV Substation during on-site commissioning tests. 10th International Symposium on High Voltage Engineering, Montreal 1997
- [8] Schuon, E., Wolf, H.: Nachrichtenmesstechnik. Springer Verlag 1981
- [9] J.R.Andrews: Picosecond pulse generators using microminiature mercury switches. NBSIR 74-377, Boulder, Colorado.
- [10] Hitoshi Okubo, Toshihiro Hoshino, and Toshihiro Takahashi, Masayuki Hikita, Akinobu Miyazaki: Insulating Design an On-Site Testing Method for a Long Distance, Gas Insulated Transmission Line (GIL). IEEE 1998 -Vol. 14, No. 6
- [11] W. Bächthold: Lineare Elemente der Höchstfrequenztechnik, vdf verlag / Zürich 1994
- [12] G. E. Valley and H. Wallman: Vacuum Tube Amplifiers, pages 77-79, McGraw-Hill Book Company, Inc., New York, 1948.